

# HT35 Mini Excavator



## New optimization and upgrading

1. The overall shape adopts tailless design, which is flexible and versatile. It works in narrow space conditions such as city streets and basements.
2. the cab adopts integrated steel structure design, the structure is safe and reliable, equipped with heating and cooling air conditioning, in order to further improve comfort, the same level of cab space standard, the space is increased to the maximum.
3. the working device has the function of skew, can be combined with the up rotation operation, the new optimization design of the working device, strengthen the skew body, and greatly improve the life.
4. the new debugging of the hydraulic system, walking compound action operation is more smooth, slope heavy rotation ability is greatly improved.



### Load-sensitive main valve:

- Highly coordinated operation and high efficiency
- Plate-type structure, flexible adjustment
- Precise control and good micro-movement
- Small pressure loss and more energy saving
- Comfortable operation



Plunger walking motor



Plunger rotary motor



Plunger pump

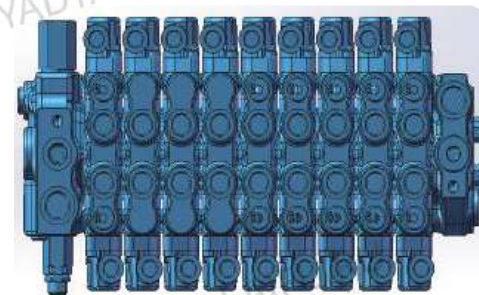

Load sensitive system, high reliability, low pressure loss, The compound action is smooth.

Model:HT35		Performance Parameter	
Transport length	4400 mm	Climbing ability	35°
Transport height	2200 mm	Max. digging force	55.6KN
Chassis width	1530/1600 mm	Travel speed	2.4/4.6km/h
Track width	300 mm	Rall contact pressure on the ground	34.8kpa(0.355kgf/8cm2)
Total track length	2175 mm	Specification	
Track gauge	1703 mm	Bucket Capacity	0.26m3
Pitom ground clearance	557 mm	Fuel reservoir	60L
		Hydraulic tank capacity	75L
		Operating Weight	3600kg
Engine		Working Range	
Engine model	ZN490	Max. Digging height	4450 mm
Power	34 KW	Max.dumping height	3050 mm
Coling method	Water- cooling Diesel engine	Max. Digging depth	2545 mm
Hydraulic system		Maximum digging distanc	4630 mm
Operating Pressure	22 mpa	Max.Digging radius	4730 mm
Walking motor	Two speed plunger	Minimum radius of gyration	1820 mm
Rotary motor	Variable plunger	Maximum lfting height of earth shovel	359 mm
The main pump	32cc Plunger 32cC	The maximum digging depth of dozer	268 mm
Flow	99/min	Min Tail swing radius	1170 mm

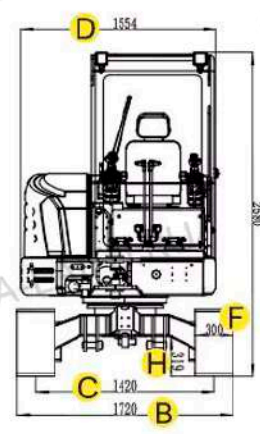
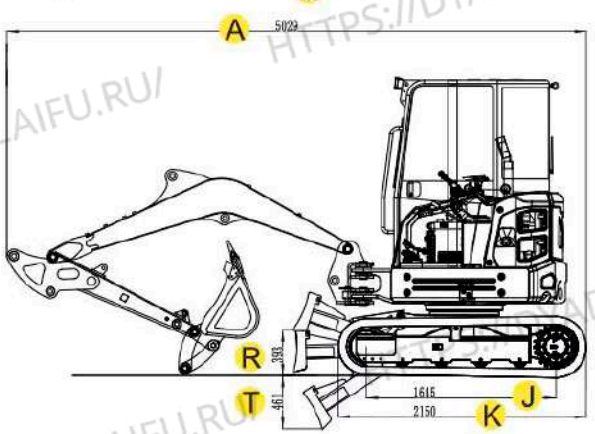
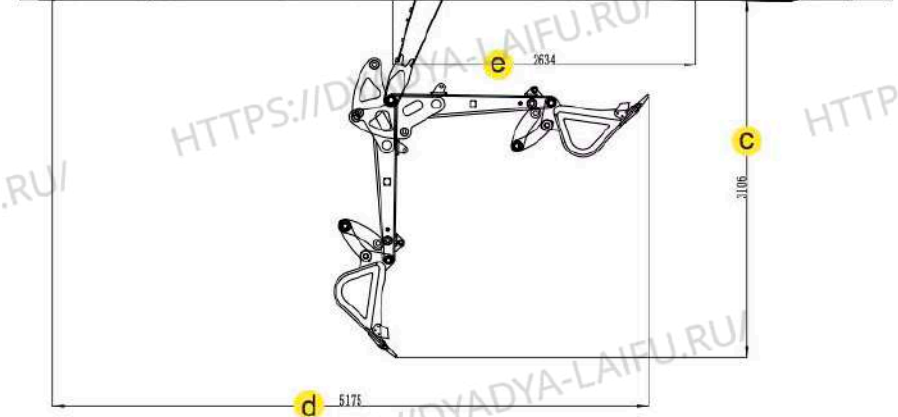
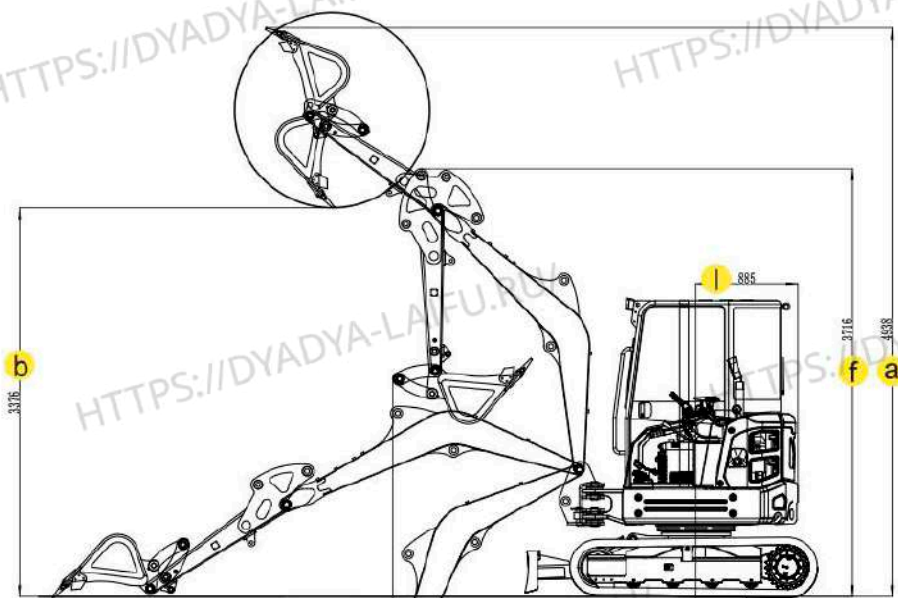

# ACCESSORIES

•One Machine, multi-usage •Quick and easy replacement of accessories



Rotary quick hitch joint



Simple quick hitch



Hydraulic rotary quick change



200mm narrow bucket with teeth



600/800/1000mm Plain bucket



600/800/1000/1200mm  
Tilt Bucket



Hydraulic quick hitch



Semi-automatic hydraulic hitch



Log splitter



Grapple



Grapple



Hydraulic rotary grapple



Ripper



Auger



Break hammer



All-in-one hydraulic thumb clamp



Mechanical thumb clamp



Hydraulic thumb clamp



Grass trimmer



Root topper



Cropper



Sand bucket



Steel track



Rake



Fork



Trailer