



RIPPA®

MINI EXCAVATOR

R32 PRO



Обзор на мини-екскаватор RIPPA R32 PRO от Дядя Лайфу

High performance, more choices.

Improved basic performance and provided many new options to better meet the needs of various fields.

Economy

**Easy operation
& Efficiency**

Environment



MINI EXCAVATOR R32 PRO

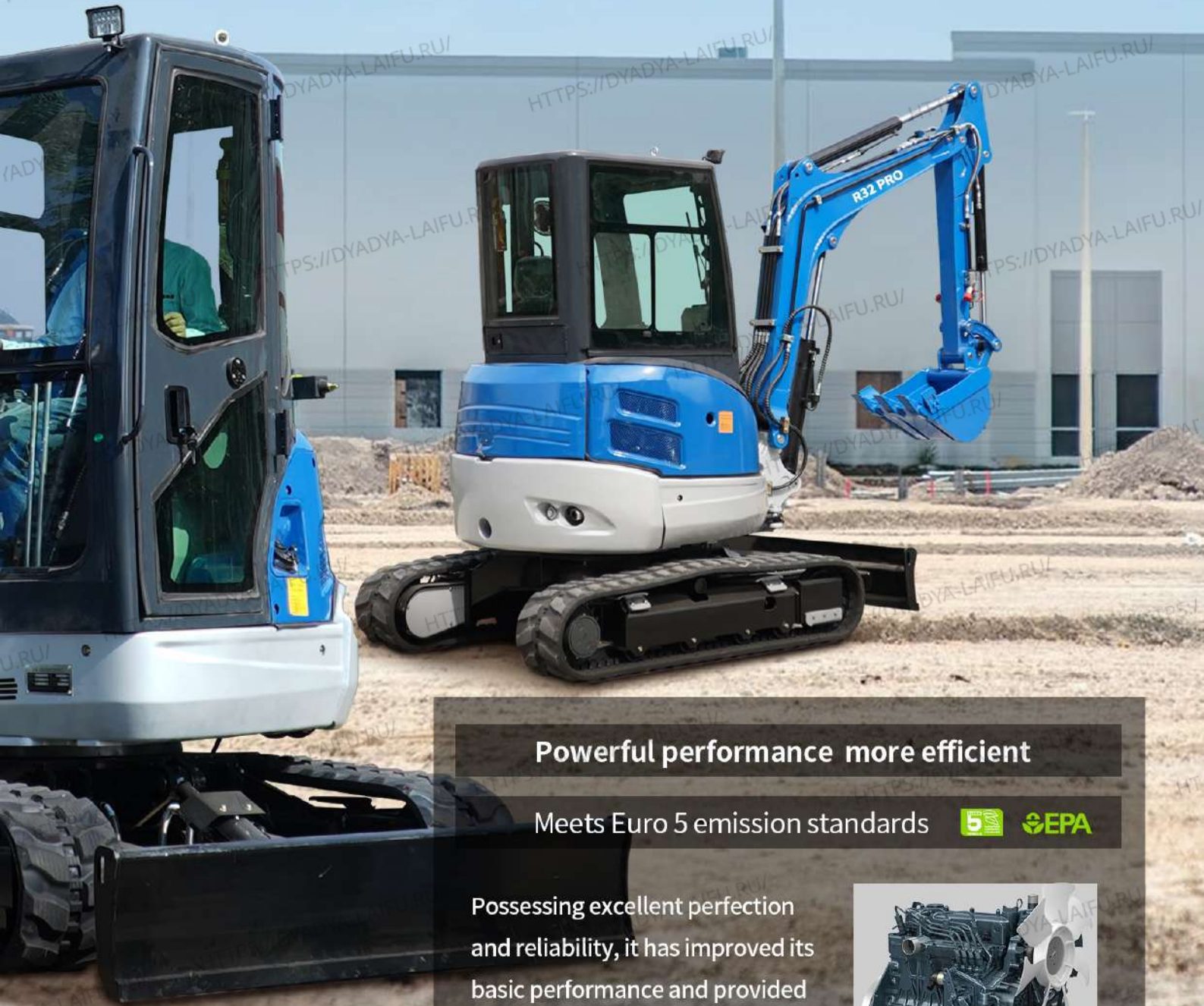

Powerful performance more efficient

Meets Euro 5 emission standards



Possessing excellent perfection and reliability, it has improved its basic performance and provided many new options to better meet the needs of various fields.



PERFORMANCE

Pursuing higher performance of machines

More energy-saving and efficient

This system controls the hydraulic oil discharge flow rate by feeding back the "pump discharge pressure" and "actuator load pressure" to the LS regulator mounted on the hydraulic pump, and supplies only the required flow rate to the control valve.



- Smooth operation thanks to lever operation and discharge adjustment according to work load.

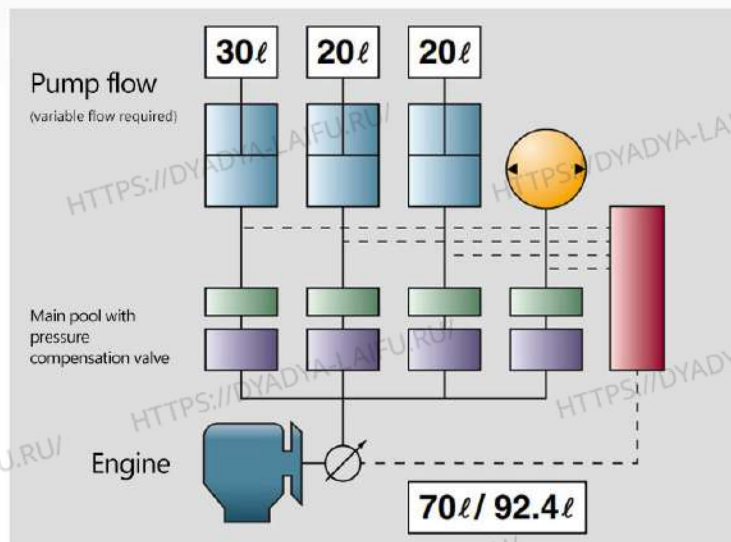

- Of the maximum discharge volume of 92.4L, it detects the required flow rate of 70L for the work equipment and discharges only 70L from the pump, so there is no waste.

fuel cost
About 5% up

※ Current machine ratio



Front digital instrument panel

The large-screen instrument panel is easy to read, and since it is placed in front of the machine, you can check various things with minimal eye movement while working. Necessary information can be displayed with simple operation, and function buttons are located below the LCD screen to improve operability.

- 1 Headlight
- 2 Working lamp
- 3 Charging Instructions
- 4 Hydraulics pressure
- 5 Fuel
- 6 Oil temperature
- 7 Battery



The hose is clean around

Restrain the looseness of boom cylinder hose to prevent damage.

Assistive device settings (standard mode)



The arm's raking position can be set in any direction, depending on the attachment. It can be easily set using the hand-held toggle button, so you can respond quickly when switching between buckets and flat-beds on site.



COMFORT/SAFETY

Safer, more comfortable and easier to operate

2-post ROPS/OPG · 4-post ROPS/OPG

Canopy, cab + seat belt



AUTO IDLE

When the control lever is returned to neutral, the engine will be in an idling state after 4 seconds, and when the control lever is moved again, the engine speed will immediately rise to the original speed. As a result, fuel can be saved by about 10%, and noise can be reduced, so work in urban areas and at night can be performed with peace of mind.

Walking pedals

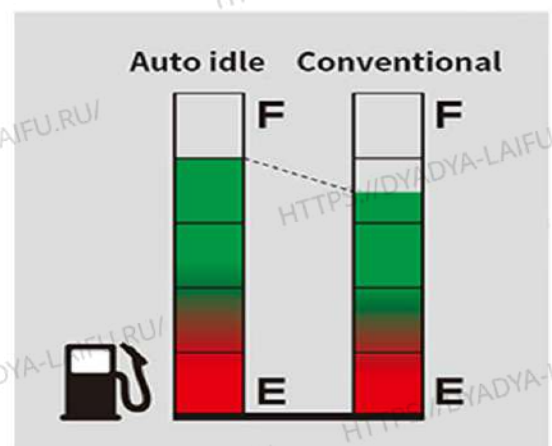
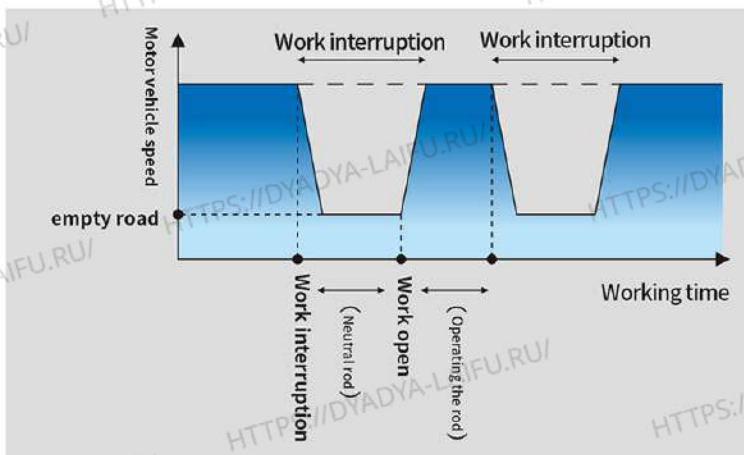



Walking speed gear

Equipped with fast and slow speed function, the driver can manually select the driving speed mode, which is suitable for a variety of operating conditions. It is more conducive to production operation and is convenient and fast.

Easy-to-operate dial type accelerator



Auto idle switch



Numerous safe specifications to prevent damage and trouble

• Waterproof connector with cover

A waterproof connector harness with a cover that exhibits a high level of waterproof performance prevents troubles in the electrical system.

• Front hose interior

The internal type prevents damage to the hose during work.

• Front hose cover

Prevents the operator from being exposed to pressurized oil in the event of a hose burst.

• Glass fiber filter

A high-precision glass fiber filter is used for the hydraulic oil filter. It has excellent dust trapping performance and is safe with little deformation and damage.

• X frame + Katayama type track frame adopted

The crawler is good at removing mud, making it easy to remove soil and wash the car.

• Divided dozer hose

By splitting the hose in the middle, maintenance and replacement of the hose can be easily performed even in the event of unexpected damage.

• Auto glow

It automatically senses the water temperature and makes it possible to start the engine with the optimum and shortest glow time.

MAINTENANCE

A reassuring, safe design that offers excellent maintainability and durability.



- 1 Air core
- 2 Oil water separator
- 3 Electric fan
- 4 Liquid oil box

Full open bonnet

The rear cover and side cover can be fully opened for easy maintenance.



Comfortable work space

Spacious boarding and alighting space with large doors make it easy to get on and off. It became smoother and the visibility of the foot during operation expanded. A bright and comfortable space contributes to reducing operator stress.

Air conditioner

The vehicle is equipped with air conditioning to provide a comfortable driving environment.



Cab specifications

LED light



OPTION

Adapt to various working environments

Soft canopy specification (R32 Pro)



R32 Pro boom length: 2220 mm

R32 Pro stick length: 1620 mm

*Long arms are reinforced on both sides only.

Rubber Engineering Tracks



It uses industrial rubber tracks, which are thick and durable and suitable for a variety of terrains.



Large Capacity Bucket

Bulldozer Blade





Front protector
(dealer option)



Comfortable cab

Assistive devices

• Hydraulic breaker



• Hydraulic fork



• Large splitting machine



• Smaller machine



Super change (standard equipment)

4 pattern multi (optional)

Different operation modes can be changed to adapt to various operating habits.

■ SCOPE OF WORK

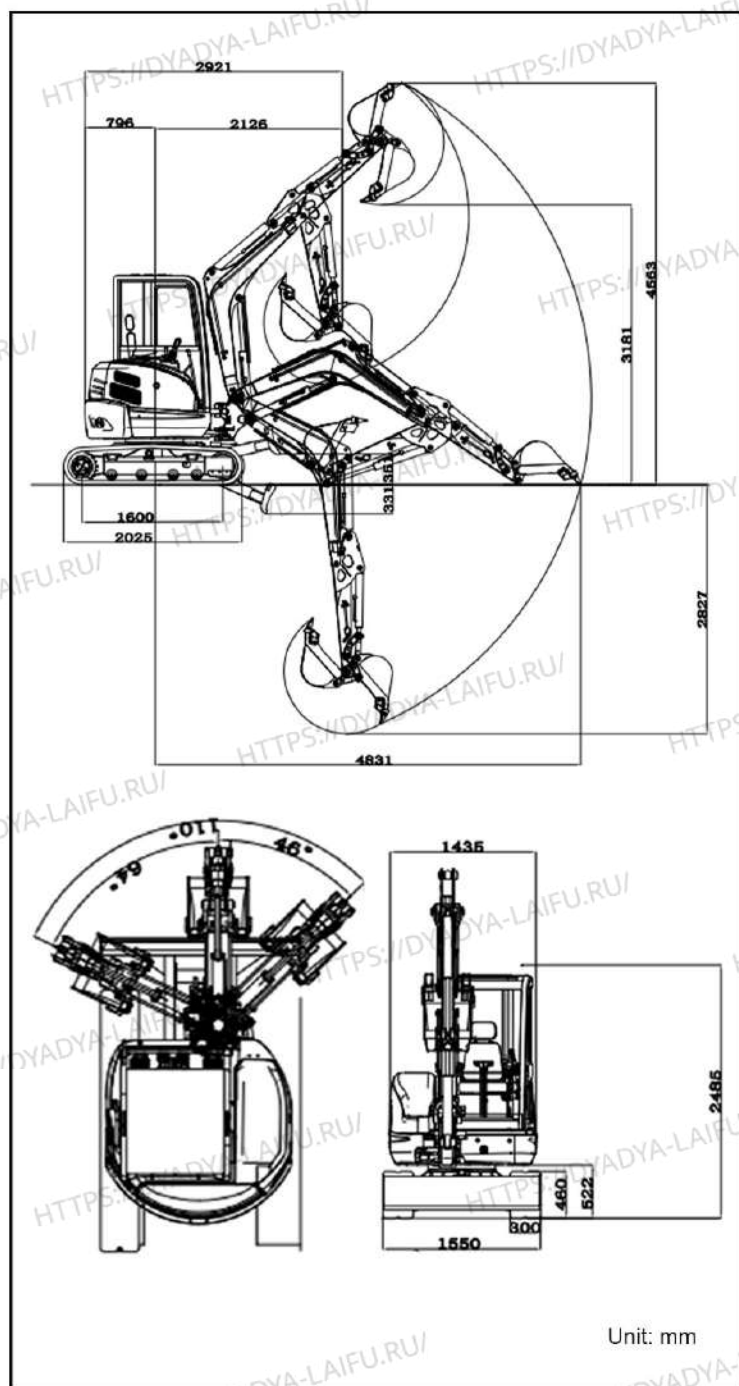

■ SPECIFICATION

Model		R32PRO
Basic parameters	Machine working weight (kg)	3171
	Bucket capacity (m ³)	0.08
	Travel speed low/high speed (Km/h)	0-1.8/0-2.8
	Gradeability (%)	30%
	Ground pressure (Kpa)	36
	Maximum digging force (kN)	27
	Maximum digging radius (mm)	4831
	Maximum digging depth (mm)	2827
	Maximum digging height (mm)	4563
	Maximum unloading height (mm)	3181
	Maximum deflection angle (°)	110
	Track extension range (mm)	-
Engine	Engine brand	Kubota
	Engine model	V1505
	Maximum horsepower (ps)	25
	Maximum power (Kw)	18.5
	Maximum speed (rpm)	2300
	Displacement (L)	1.5
	Number of cylinders	4
	Cooling method	Water-cooled
	Engine oil change amount (L)	6
	Fuel form	Diesel
	Fuel grade	0/-10
	Theoretical fuel consumption (L/h)	1.3-1.5
Body	Transport length (mm)	2921
	Transport width (mm)	1550
	Transport height (mm)	2485
	Counterweight ground clearance (mm)	522
	Bucket width (mm)	400
	Boom length (mm)	2220
	Arm length (mm)	1620
	Bulldozer blade width (mm)	1550

■ HYDRAULIC SYSTEM

Main pump type/model	Load sensitive piston pump/45
Main pump brand	Taifeng
Main pump maximum flow rate	99 L/min
Multi-way valve	Load sensitive 9-way hydraulic multi-way valve
Multi-way valve brand	Taifeng
Rated set pressure	18MPa

Maximum set pressure (Mpa)	20MPa
Travel hydraulic motor type	LTM03AX
Travel motor brand	Likechuan
Motor displacement	15.4/23.2
Slewing hydraulic motor type	Likechuan
Displacement	18.1

- GESTION HJPlease read the instruction manual carefully and use the machine correctly.
- Always wear a seat belt when working. (ROPS specifications only)
- If you are operating construction machinery with a machine mass of less than 3 tons, you must take the "Special Training for Vehicle-Mounted Construction Machinery Operation" course beforehand. If the machine mass is 3 tons or more, you must take the "Vehicle-Mounted Construction Machinery Operation Skills Course".
- To prevent breakdowns and accidents, be sure to inspect the machinery regularly.
- Specific voluntary inspections are required to be carried out by an inspection company registered with the Minister of Health, Labor and Welfare or the Director-General of the Labor Standards Inspection Bureau.