



**RIPPA**

RIPPA GROUP

**R22 PRO**



Обзор на мини-экскаватор RIPPA R22 PRO от Дядя Лайфу



# Further improve work efficiency

The R22 PRO, which prides itself on its excellent finish and overwhelming trust, has unveiled its long-awaited crane specifications. While improving work efficiency, it also has environmentally friendly properties such as low fuel efficiency, low vibration, and low noise. The pursuit of driver-centered safety and the use of advanced digital instruments for operability all add to the mature flavor.





# NEW MODEL DEBUTS

# R22PRO



**Comply with European exhaust gas fifth emission standard**

**Comply with U.S. EPA exhaust emission standards**

The machine is equipped with an environmentally friendly engine. It meets Euro V and EPA emission standards, is fuel-efficient, low-noise, and can achieve high power output. Durability, safety and comfort are comprehensively upgraded. Compact design delivers powerful performance. The excellent performance brought by the abundant torque greatly contributes to the improvement of workability.





# PERFORMANCE

Outstanding power and smooth operation for superior operability

Powerful digging force and 4-way operation

NEW-H · M · S hydraulic system

Adopts a 3-pump system that uses independent pumps for the boom, arm, and swing, and is equipped with a control valve with a wide control range and a variable displacement pump. With smooth, quick, and powerful work, we can meet even the toughest demands at a high level.

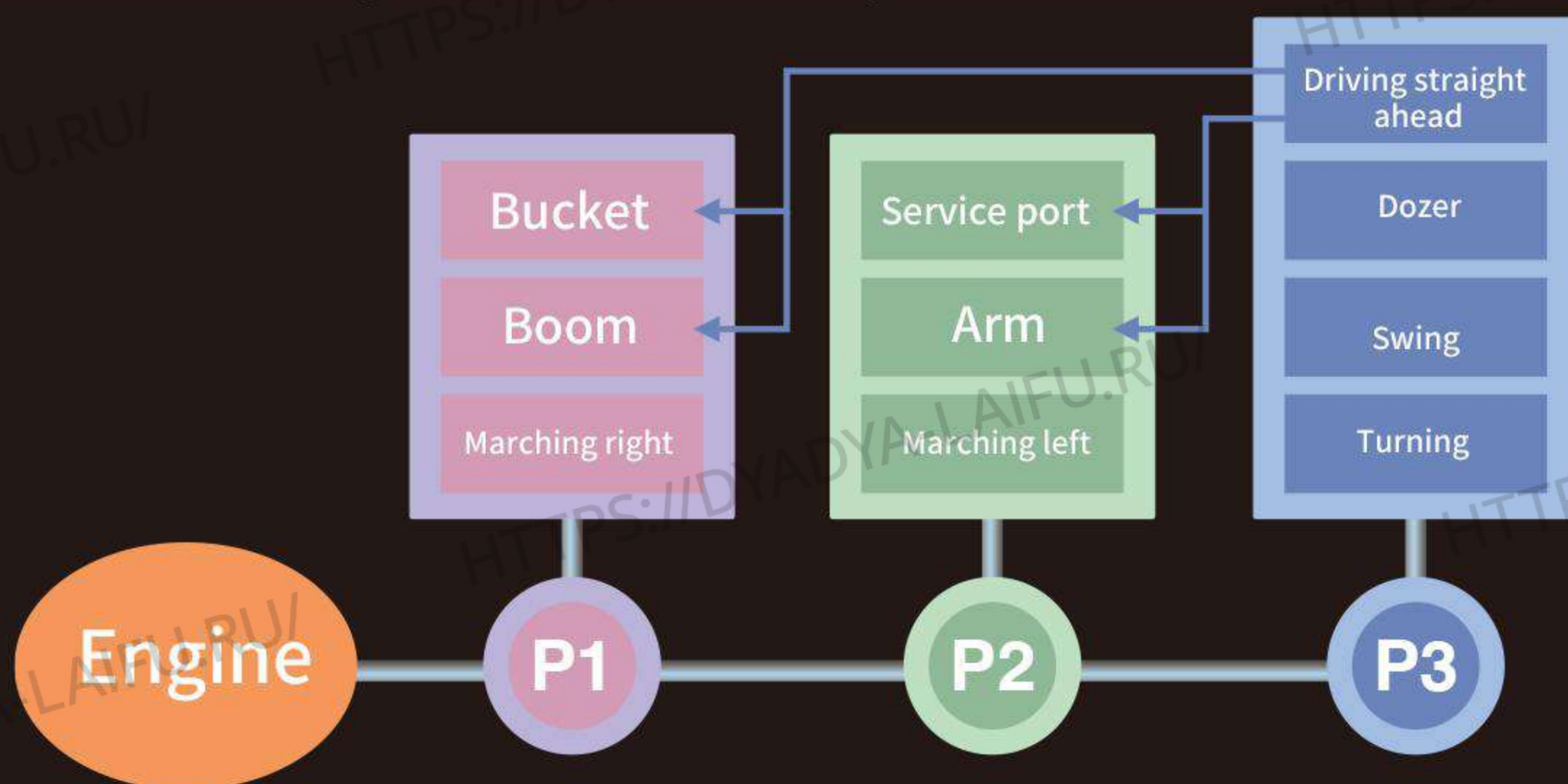

## ● Powerful drilling performance

Concentrates hydraulic power to the front and delivers powerful digging power.

## ● Equipped with a straight running circuit

Even if you operate the front while driving, there is no meandering or speed change, and stable straight-line driving is achieved.

## ● 4 consecutive operations possible

The optimal matching of the 3 pump system and hydraulic system allows simultaneous operation of the bucket, boom, arm, and rotation.

## ● Easy to load and unload on truck





● Options for crane specifications

Bucket cylinder cover

Arm cylinder cover

Обзор на мини-экскаватор RPPA R22 PRO от Дядя Лайфу

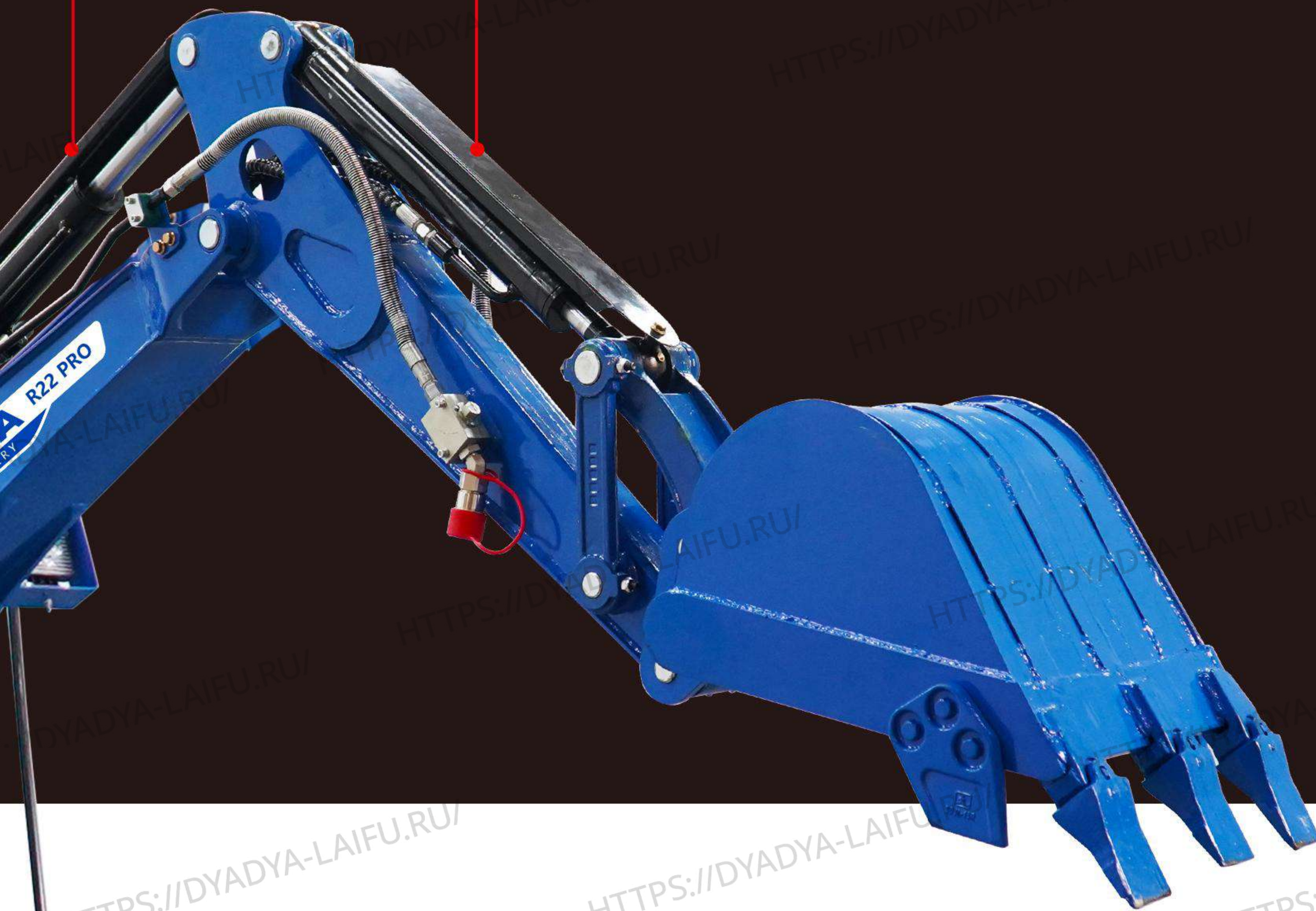

Variable leg specifications (optional)

Convenient R22 PRO

Vehicle width when reduced: 1300mm

Variable leg specifications in consideration of situations where the approach road is narrow. It exhibits high stability by being compact at 1,300mm when traveling and transporting, and of course expanding to 1,500mm when working.



Compact when traveling and transporting  
**Reduced to 1,300mm**

Improved stability during excavation work  
**Expanded to 1,500mm**

Approaching the 3t class

Suitable for 2.5 liters R22 PRO

● Although it is a 2.5t class machine, it exhibits excavation performance and stability approaching that of a 3t class machine. Contributes to increased efficiency with work capacity that exceeds that of its class.

● Achieves speedy front movement by constantly optimizing hydraulic pressure distribution. Combination work can be done extremely smoothly.

● Designed in pursuit of excellent stability, it is effective when attaching attachments or on sites that involve lifting work.

● The service port has ample oil flow capacity, making it compatible with attachments such as breakers. It responds to harsh use with stable operation. (Service port specification option)



\*The photos shown are for the catalog with options installed. Ground the work equipment when leaving the site.



# WHILE IMPROVING HOMEWORK EFFICIENCY, ACHIEVE LIVABILITY AND SAFETY.

TWO PILLARS / OPG • FOUR PILLARS / OPG

CANOPY CAB + SEAT BELT

For TOPS/ROPS/OPG that pursue operator safety, please use the Canopi Cabs (with seat belts) corresponding to Do Level I to further pursue safety. Implement a safety structure to protect the operator in case of a fall. The design of the boarding and alighting space is spacious, and getting on and off is also very easy. At the same time, sudden falling objects on site are also protected.

## ① CAB STANDARD EQUIPMENT

Front tempered glass / front window open / ashtray / heater

※ Tops: protect over protective structures

The structure to protect the driver with the seat belt mounted in the roll. fitted to the test conditions of the mini shovel overturn protection structure.

※ OPG (top guard): Structure to protect drivers from falling objects. is suitable for test conditions of top guard level.

※ ROPS: roll over protective structures

Structure to protect the driver with seat belt when falling. earthenware machine - suitable for test conditions of overturning protection structures.



One touch easy operation

Digital meter panel

One hour operation of the display switch is displayed on the liquid crystal screen. By displaying the error code of the liquid crystal screen and warning lamp lighting, the operator immediately notifies the operator of overheating, abnormality of the hydraulic system and abnormality of the charging system. Simple design, easy access and easy to read indicators allow operators to always grasp the state of the machine.



battery power



Oil volume



Hydraulic oil





# COMFORTABLE CAB



## FULL OPEN BONNET

The rear and right side bonnets can be opened wide without tools, allowing quick daily inspection and maintenance of the engine and fuel system. In addition, the inspection and maintenance points for the hydraulic system are centrally located on the right side of the aircraft, dramatically improving work efficiency.

## LOOSE FEELING!

## COMFORTABLE OPERATION

Ensure spacious foot space and support leisurely and smooth operation. The same operating feeling as a mainframe, achieving stress free operation.

## Comfortable work space



## Herringbone track

Engineering rubber tracks can be matched with high-quality wear-resistant steel tracks for smooth walking



## Air conditioner

The cab specification is equipped with an air conditioner as standard, providing a comfortable working environment at all times, even during the mid-summer and extreme cold seasons. hydraulic and fuel.





# MAINTENANCE

Smart maintenance and reliable durability.

## Simply switch on and off

### Double opening engine hood

Due to the lack of tools to significantly open the rear and right upper covers, daily inspections and maintenance around the engine and fuel system are simply possible. During the formal overhaul, the disassembly of the rear and right engine covers can be carried out quickly and accurately within just a few minutes, and the internal inspection and overhaul can be carried out quickly and accurately.

## Sturdy front

The front end, root, swing pivot, and travel motor support of the boom subjected to heavy loads during homework are reinforced with cast steel materials to enhance strength. In addition, the front fulcrum is reinforced by a large diameter front fulcrum pin.

Air filter

Water tank

Diesel filter

Heat sink

Diesel tank

Battery

Oil tank

Oil filter

Oil cooler

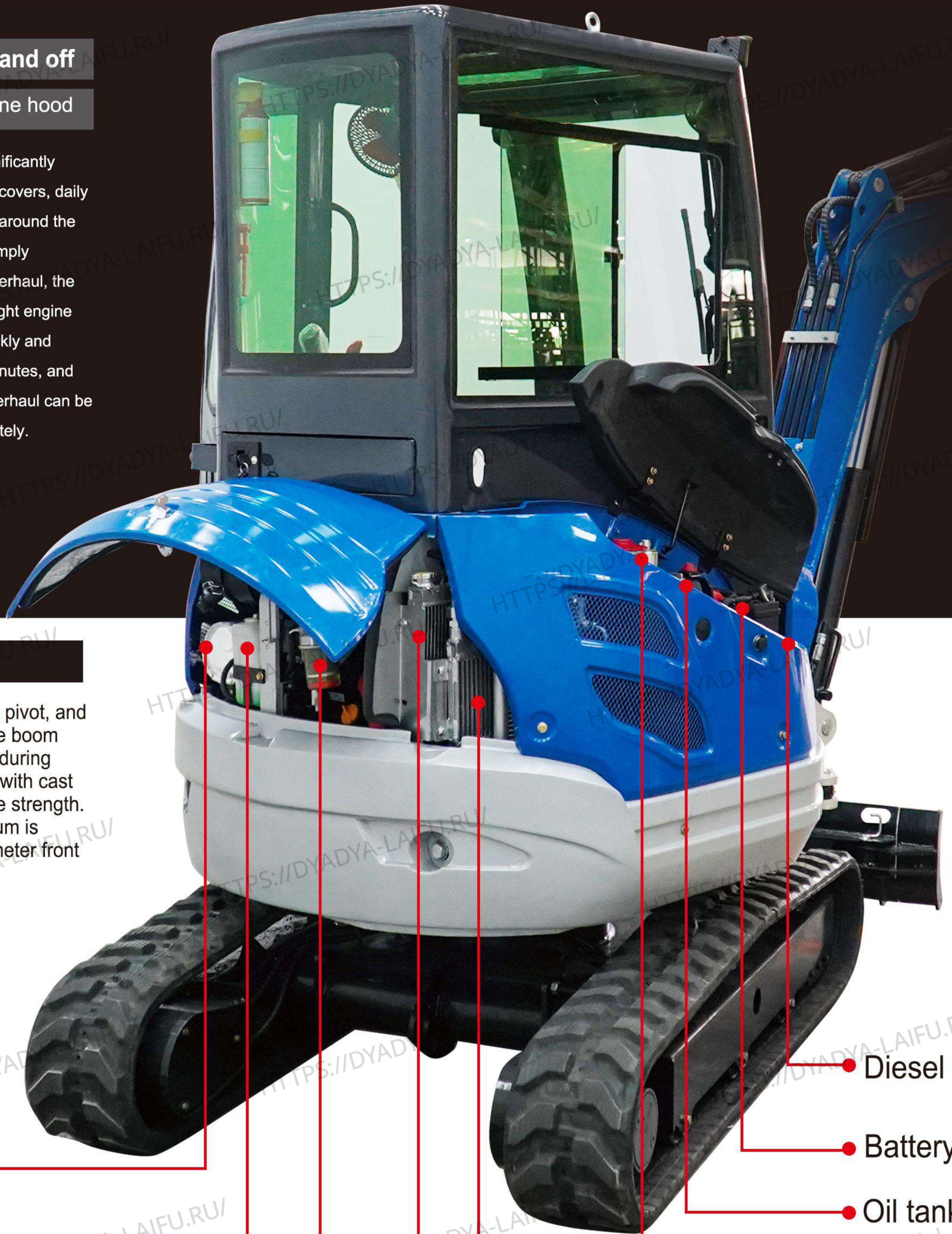



## ■ SCOPE OF WORK

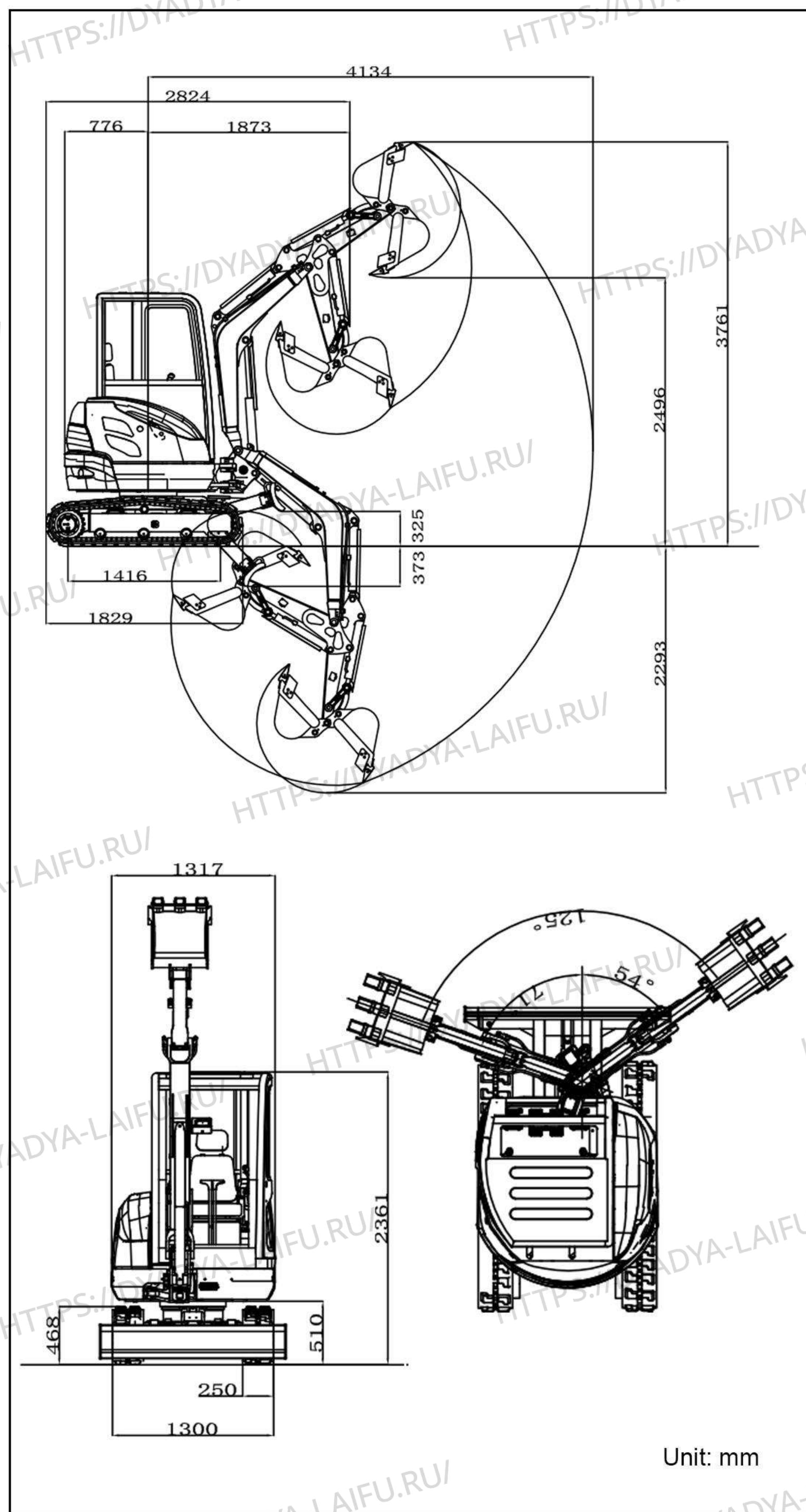

## ■ SPECIFICATION

|                                    | Model                               | R22PRO                |
|------------------------------------|-------------------------------------|-----------------------|
| Basic parameters                   | Machine working weight (kg)         | 2371.5                |
|                                    | Bucket capacity (m <sup>3</sup> )   | 0.054                 |
|                                    | Travel speed low/high speed (Km/h)  | 0-1.5/0-2.8           |
|                                    | Gradeability (%)                    | 30%                   |
|                                    | Ground pressure (Kpa)               | 33.4                  |
|                                    | Maximum digging force (kN)          | 18.4                  |
|                                    | Maximum digging radius (mm)         | 4143                  |
|                                    | Maximum digging depth (mm)          | 2293                  |
|                                    | Maximum digging height (mm)         | 3761                  |
|                                    | Maximum unloading height (mm)       | 2496                  |
|                                    | Maximum deflection angle (°)        | 125                   |
|                                    | Track extension range (mm)          | 1300-1500             |
|                                    | Engine                              | Engine brand          |
| Engine model                       |                                     | D1105                 |
| Maximum horsepower (ps)            |                                     | 24.75                 |
| Maximum power (Kw)                 |                                     | 18.2                  |
| Maximum speed (rpm)                |                                     | 3000                  |
| Displacement (L)                   |                                     | 1.123                 |
| Number of cylinders                |                                     | 3                     |
| Cooling method                     |                                     | Water-cooled          |
| Engine oil change amount (L)       |                                     | 4.2                   |
| Fuel form                          |                                     | DIESEL                |
| Fuel grade                         |                                     | 0/-10                 |
| Theoretical fuel consumption (L/h) |                                     | 1.3-1.5               |
| Body                               |                                     | Transport length (mm) |
|                                    | Transport width (mm)                | 1300                  |
|                                    | Transport height (mm)               | 2361                  |
|                                    | Counterweight ground clearance (mm) | 510                   |
|                                    | Bucket width (mm)                   | 450                   |
|                                    | Boom length (mm)                    | 1830                  |
|                                    | Arm length (mm)                     | 1250                  |
|                                    | Bulldozer blade width (mm)          | 1300                  |

## ■ HYDRAULIC SYSTEM

|                                |  |
|--------------------------------|--|
| Main pump type/model           | Load sensitive variable piston pump/28 |
| Main pump brand                | Taifeng                                |
| Main pump maximum flow (L/min) | 67.2                                   |
| Multi-way valve                | 9-way hydraulic multi-way valve        |
| Multi-way valve brand          | Taifeng                                |
| Rated set pressure (Mpa)       | 18MPa                                  |

|                              |           |
|------------------------------|-----------|
| Maximum set pressure (Mpa)   | 20MPa     |
| Travel hydraulic motor type  | LTM03CDK  |
| Travel motor brand           | Likechuan |
| Motor displacement           | 11-20     |
| Slewing hydraulic motor type | Likechuan |
| Displacement                 | 15.1      |

- Please read the instruction manual carefully and use the machine correctly.
- Always wear a seat belt when working. (ROPS specifications only)
- If you are operating construction machinery with a machine mass of less than 3 tons, you must take the "Special Training for Vehicle-Mounted Construction Machinery Operation" course beforehand. If the machine mass is 3 tons or more, you must take the "Vehicle-Mounted Construction Machinery Operation Skills Course".
- To prevent breakdowns and accidents, be sure to inspect the machinery regularly.
- Specific voluntary inspections are required to be carried out by an inspection company registered with the Minister of Health, Labor and Welfare or the Director-General of the Labor Standards Inspection Bureau.